

The Role of Autograiners in the Construction and Operation of Roads

Uktamov Sardor Makhmudjonovich

Teacher, Namangan State Technical University

sardoroktamov29101991@gmail.com

Annotation

As is known, the development of the national economy is closely linked with the expansion of the road network, the maintenance, repair, and reconstruction of existing highways. Implementation of these measures based on highly efficient road construction equipment and machinery will ensure significant savings in materials, energy, and labor resources in the national economy of the republic.

Keywords: grader, dump truck, blade, wheel, engine, platform, cardan, hydraulic cylinder, frame, cab, gearbox.



This is an open-access article under the [CC-BY 4.0](https://creativecommons.org/licenses/by/4.0/) license

Introduction: The development of construction and road machinery in the Republic of Uzbekistan is aimed at increasing the technical level of construction production and the production of machines, mechanisms, tools, and other products that allow for a sharp reduction in the use of manual labor. It is necessary to ensure the production of a system of machines, means of mechanization, and tools necessary for the complex mechanization of construction processes. By increasing labor productivity, it is planned to increase production volumes. This is associated with increasing the technical level of manufactured machines and equipment, reducing the time for conducting scientific research and design and technological developments based on scientific and technical achievements and best practices.

Scientific and technological progress in construction, road, and household machinery production is mainly due to the technical re-equipment of enterprises, the introduction of new technological processes and adaptations into production.

Research Method: Avtogreyders are self-propelled machines for leveling and shaping soil, the working unit of which is a fully rotating blade dump located between the rear and front axles of the pneumatic-wheeled drive unit.

In addition to the main fully rotating dump truck, graders are equipped with additional working equipment - a cultivator-scraper or a bulldozer dump truck installed in front of the front wheels. Various variable working equipment can also be installed on them: slope, snow remover, road milling cutter, grader-elevator equipment.



Figure 1. Overview of the SEM922 AWD Autograder, equipped with an additional ripper and bulldozer dump

Graders are classified according to their structural mass as light (up to 9 tons), medium (up to 13 tons), and heavy (up to 19 tons), and according to the wheel layout, determined by the wheel formula $A \times B \times V$ (where A is the number of axles with the driven or control wheel, B is the number of axles with the driven wheel, and V is the total number of axles).

Light graders are used for maintenance and routine repair of roads, medium graders for repair and construction of roads and other earthworks in moderate soil conditions; heavy graders are advisable for large-scale road works, construction of airfields, and work on heavy soils up to group III.

When operating graders on different slopes, the front wheels can be installed sideways on both sides to increase stability and reduce the turning radius.

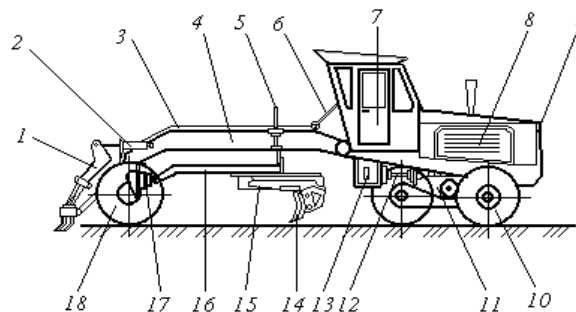

Figure 2. Overview of the grader

1 - additional equipment - scraper; 2.5 - hydraulic cylinder; 3 - pipeline; 4 - frame; 6 - cabin; 7 - door; 8 - engine; 9 - platform; 10 - cylinder; 11 - balancer; 12 - cardan; 13 - gearbox; 14 - turner; 15 - turning circle; 16 - cardan; 17 - drive; 18 - front cylinder.

Road graders are road construction machines belonging to the class of earthmoving and transporting machines. With the help of road graders, it is possible to perform the following work in road engineering:

- ✓ in preparatory work (cutting the vegetation layer, leveling the roadbed);
- ✓ construction of highways (in the construction of earthworks, the foundation of road pavements);
- ✓ routine maintenance of roads (strengthening of roadsides, removal of damaged asphalt concrete pavements);

- ✓ maintenance of roads (removal of weeds and shrubs growing on roadsides and pavements, edge finishing, restoration);
- ✓ during winter maintenance of roads (cleaning the roadway and roadside from snow).

Research results and discussion. When profiling a road, the grader sequentially cuts the soil in the trough, moves it along passages parallel to the road axis, plans and finishes the profile.

Productivity of graders for cutting and moving soil (m³/h):

$$P_{alg} = \frac{60 \cdot L \cdot F_x}{T_s}$$

here: F_x - area of the soil section formed in one pass, m²; for medium-sized graders $F_x=0.5...0.09$ m³; for heavy graders $F_x=0.07...0.12$ m²; L - working length, meters, when finishing soils, we assume $L=400-500$ m; T_s - time of the working cycle.

The working cycle of graders is determined by the formula:

$$T_s = 2L \left(\frac{n_1}{v_1} + \frac{n_2}{v_2} + \dots + \frac{n_i}{v_i} \right) + 2nt_{bur}$$

here:

n_1, n_1, \dots, n_i - the number of passes during soil cutting, leveling, and finishing operations, respectively;

v_1, v_2, \dots, v_i - respectively, the velocities of the soil during cutting, leveling, and finishing operations, m/min;

time required for auxiliary operations, minutes, time required for grader rotation, or time spent on turning the working equipment (turner) by 90° at the end of the field (1...2.5 minutes).

The working speed of graders depends on the type of work performed, and they are performed at a speed of 3...4 km/h for cutting, 3...6 km/h for moving, and 3...4 km/h for finishing, respectively.

Summary. The role of graders in the construction, repair, maintenance, and winter maintenance of highways is invaluable. Therefore, by using digital technologies when using motor graders, it is possible to increase their productivity and extend the technical condition and service life of roads by improving the quality of work. The use of a new generation of graders in the construction and operation of highways is relevant today.

List of references

1. И.И. Леонович, А.Я. Котлобай. Машины для строительства, ремонта и содержания автомобильных дорог.– 2005.
2. Максудов З.Т. “Кутариш-ташиш, йўл қурилиш машиналаридан фойдаланиш” фани замонавий таълим технологияси. Тошкент, 2011, 159 бет.
3. Т.И.Асқархо‘jayev, Х.Н.Диметов, Р.О .SHukurov, А.О.Икромов, С.И.Иброхимов,З.О.Мақсудов, М.Т.Умиров. Yo‘l qurilish materiallaridan foydalanish. Toshkent, 2011, 324 bet.
4. Асқархўжаев Т.Э. Шукуров Р.У Йўл қурилиш машиналаридан фойдаланиш. Тошкент, Шарк, 2007 й., 327 б.
5. Асқархўжаев Т.Э. Ер қазииш ва йўл қурилиш машиналарининг ҳисоби ва назарияси. Тошкент. Фан ва технология. 2006 й., 272 б

6. Тожиев А. Қурилиш машиналари. Тошкент. 2000, 300 б.
7. Акбаров А. Қурилиш машиналари. Тошкент 1993, 235 б.
8. Баловнев В.И. и др. Дорожно-строительные машины и комплексы. СибАДИ. Омск 2001, 204 стр.