

A Device for Uncovering (Opening) Buried Grapevines

M. I. Yasharov

Doktorant (PhD), Andijan Institute of Agriculture and Agrotechnologies

I. G. Mirzayev

Professor, Candidate of Technical Sciences, Andijan Institute of Agriculture and Agrotechnologies

Z. T. Zulunov

Assistant, Andijan Institute of Agriculture and Agrotechnologies

Y. S. Muqimova

Student, Andijan Institute of Agriculture and Agrotechnologies

Received: 2025, 04, Oct
Accepted: 2025, 05, Nov
Published: 2025, 30, Dec

Copyright © 2025 by author(s) and Bio Science Academic Publishing. This work is licensed under the Creative Commons Attribution International License (CC BY 4.0).
<http://creativecommons.org/licenses/by/4.0/>



Open Access

Annotation: The article presents the design and operating principles of a device intended for uncovering soil-covered grapevine shoots in early spring in viticultural farming enterprises.

Keywords: grape, grapevine, soil covering of grapevines, uncovering, uncovering device, fan, blade, gearbox, cardan shaft, air flow.

At present, in our country, the initial stage of mechanization of fruit and grape production processes is being implemented on the basis of intensive technologies. Existing foreign-made mini-tractors, as well as working implements and machines adapted to them, are being used. However, this does not ensure full mechanization of the sector. Power units also vary widely and do not fully correspond to the soil and climatic conditions of our country and to intensive technologies for cultivating fruit and grape crops

In agricultural production, with the use of machines aggregated with the available power units, about 424 thousand hectares of the republic's agricultural land are cultivated, including 225 thousand hectares of orchards and 149 thousand hectares of vineyards.

Professors, teaching staff, and basic doctoral students of our department take an active part in

solving the above-mentioned tasks.

The work is being carried out on the basis of an economic (contractual) agreement between the Andijan Institute of Agriculture and Agrotechnologies and the grape-growing farm ‘Do‘lanalik Bog‘bon Mevasi’ of Bulakbashi District

At present, two variants of a machine for uncovering soil-covered grape shoots have been developed at the institute’s training and experimental park. These machines have undergone preliminary experimental testing, and an act of transfer to a farming enterprise and implementation into production is currently being prepared.

Grapevine is one of the most widely cultivated agricultural crops in Uzbekistan. The presence of favorable soil and climatic conditions in the country has contributed to the formation of a diverse range of local grape varieties.

After planting, grapevines begin to bear fruit in the 3rd–4th year. A drawback of this crop is its low resistance to winter cold. Therefore, in most regions of our country, grape bushes are buried during the winter period and uncovered in spring without the use of mechanization, that is, using manual labor.

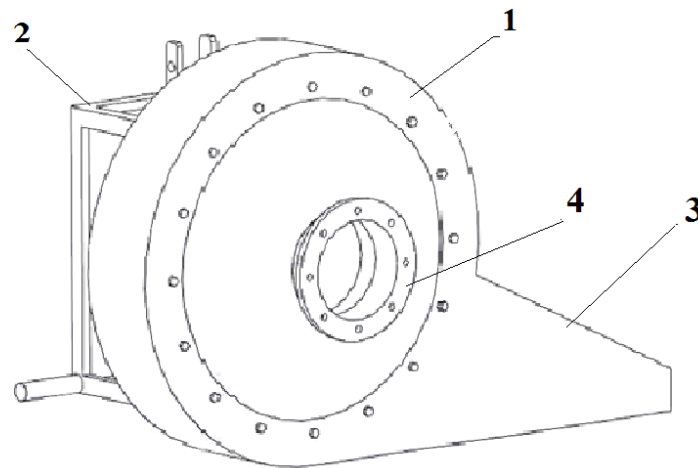

Figure 1. Schematic diagram of the device for uncovering buried grapevines.

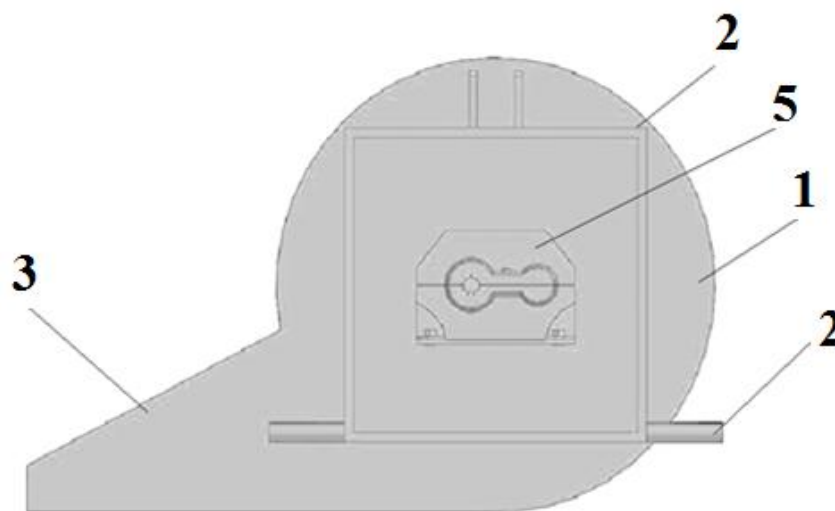

Figure 2. Schematic diagram of the device for uncovering buried grapevines (rear view)

1 – housing of the uncovering device;

- 2 – mechanism for mounting the device on the tractor;
- 3 – zone for directing the air flow toward the buried grapevines;
- 4 – air inlet to the fan;
- 5 – gearbox for motion transmission.

In early spring, a pneumatic device is used to remove soil from grapevines that were buried in autumn. The pneumatic device, aggregated with a tractor, is driven by the tractor's power take-off (PTO) shaft. As a result of the rotation of the fan of the pneumatic device, an air flow is generated. The resulting high-pressure air flow is directed onto the soil covering the grapevines. Under the action of the high-pressure air stream, the soil is displaced, the upper soil layer above the grapevines is loosened and thrown aside. As a result, the buried grapevines are uncovered, and the expected technological effect is achieved.

prototype of the device for uncovering buried grapevines was manufactured, and its laboratory tests were carried out at the institute. Representatives of the grape-growing farm 'Do'lanalik Bog'bon Mevasi' of Bulakbashi District took part in the tests. The test results were evaluated positively..

The device for uncovering buried grapevines has the following design: an outer housing, a mechanism for aggregation with a tractor, a double-row fan, fan blades, an air-flow directing mechanism, cardan (drive) shafts, and gearboxes that transmit motion to the fan.

Conclusion. The application of the device for uncovering buried grapevines, developed for grape-growing farms, makes it possible to reduce the volume of manual labor and labor costs, decrease material expenses, and, most importantly, significantly shorten the time required for the grapevine uncovering process

USED REFERENCES

1. **Temurov, Sh.** *Viticulture*. State Scientific Publishing House "Uzbek National Encyclopedia." Tashkent, 2002. — 200 p.
2. **Qoshnazarov, Kh.** *Use of Mechanization in Orchards and Vineyards*. Uzbekistan Publishing House. Tashkent, 1976. — 101 p.
3. **Qoshnazarov, Kh.** *Technical Means Used in Orchards and Vineyards*. "Mehnat" Publishing House. Tashkent, 1985. — 152 p.